

1

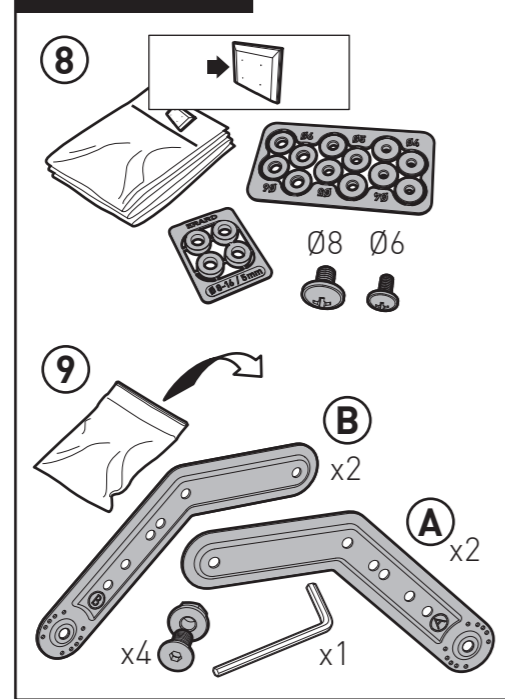

2

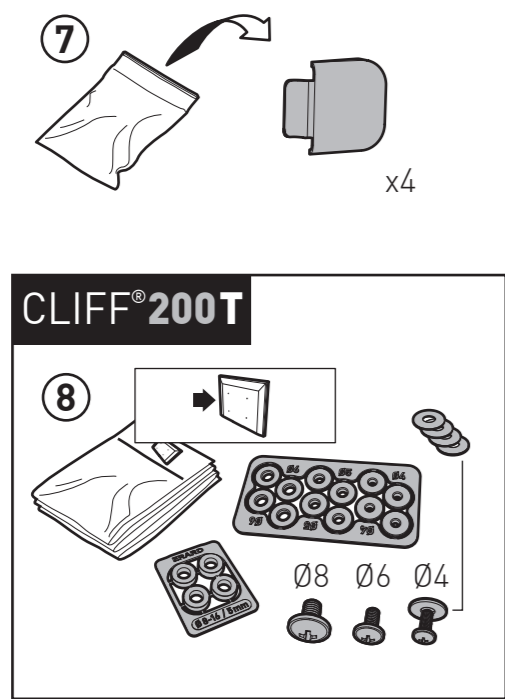
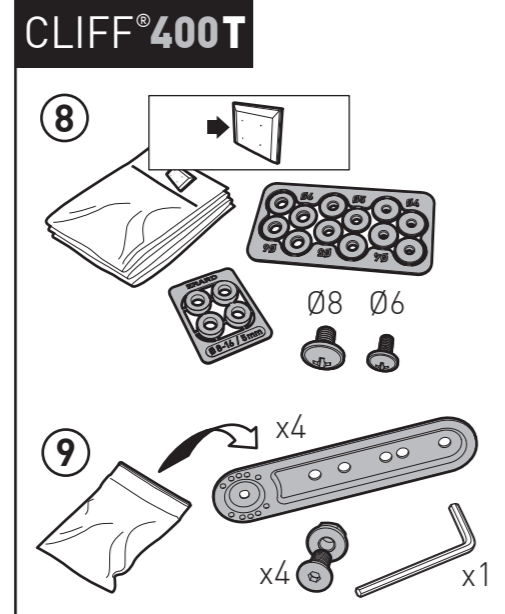
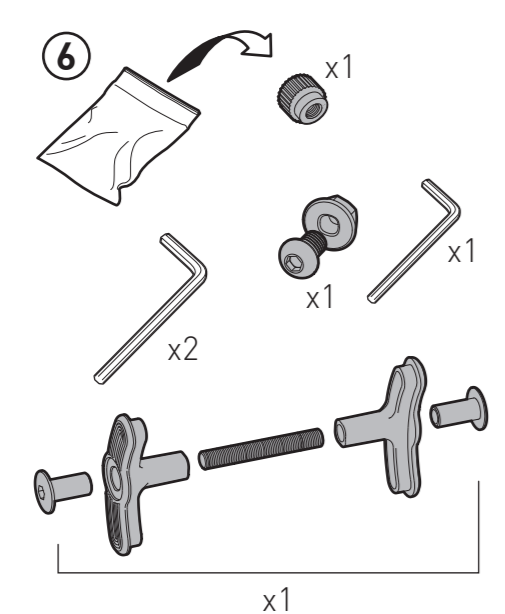
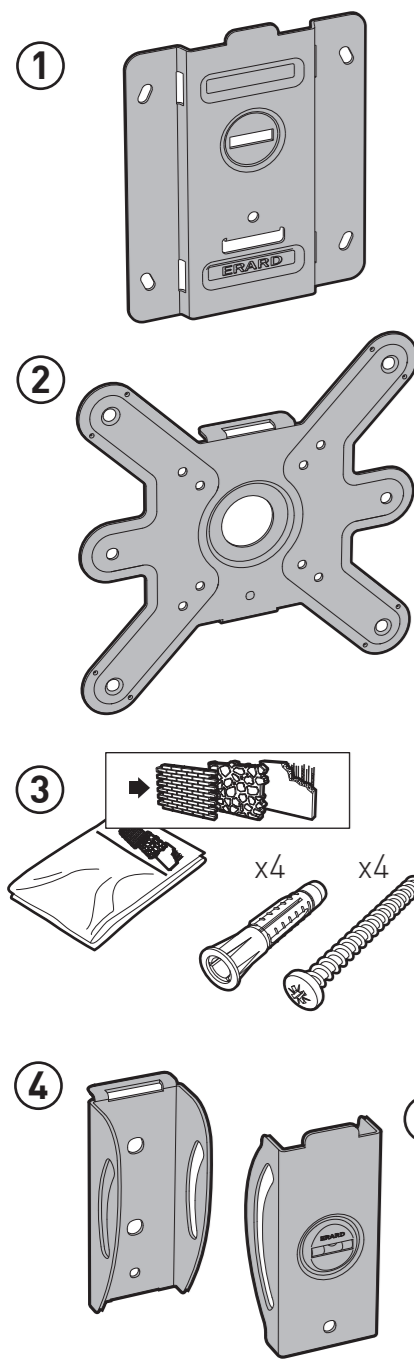
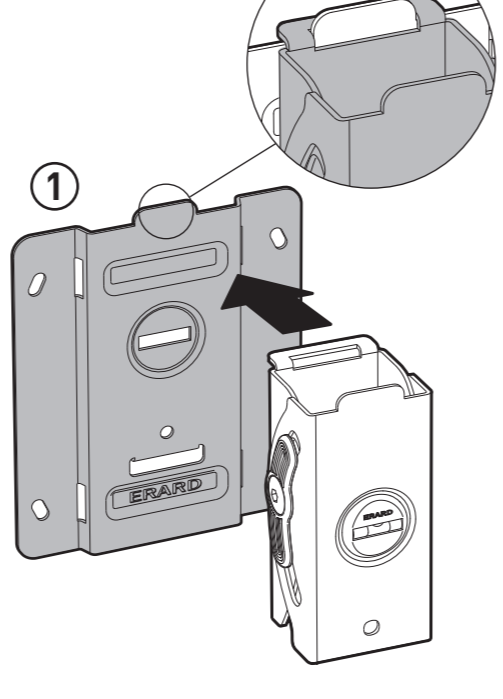
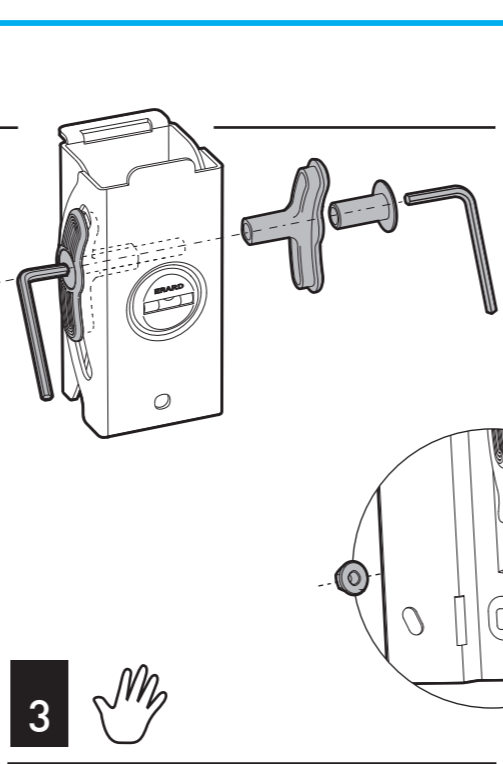
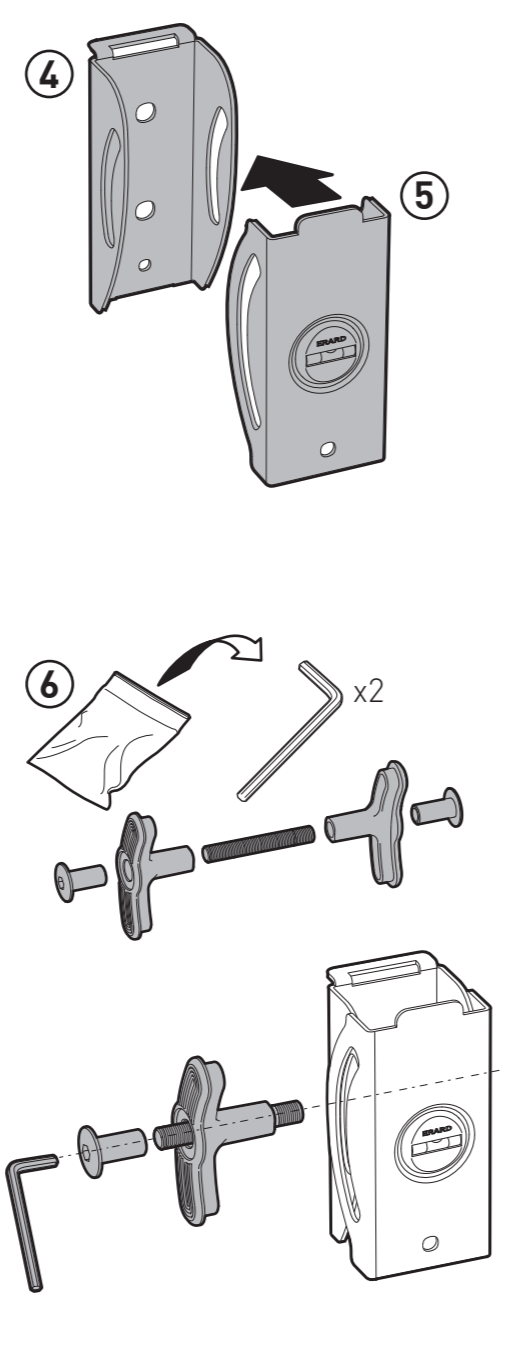

4

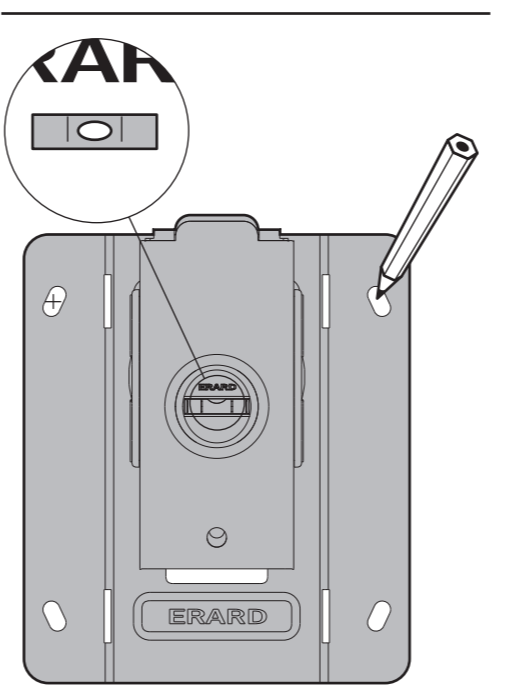
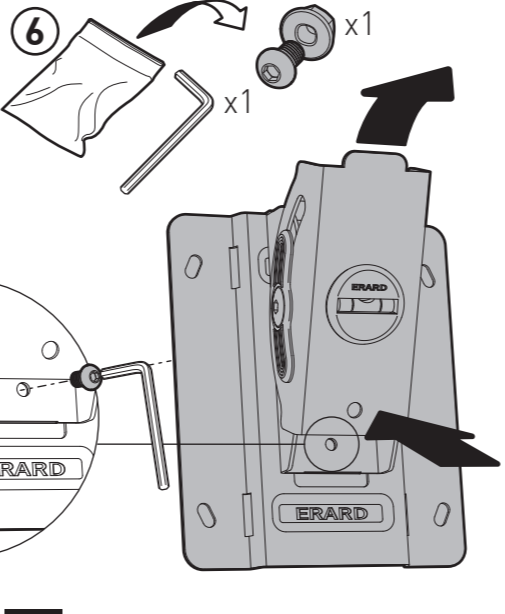

6

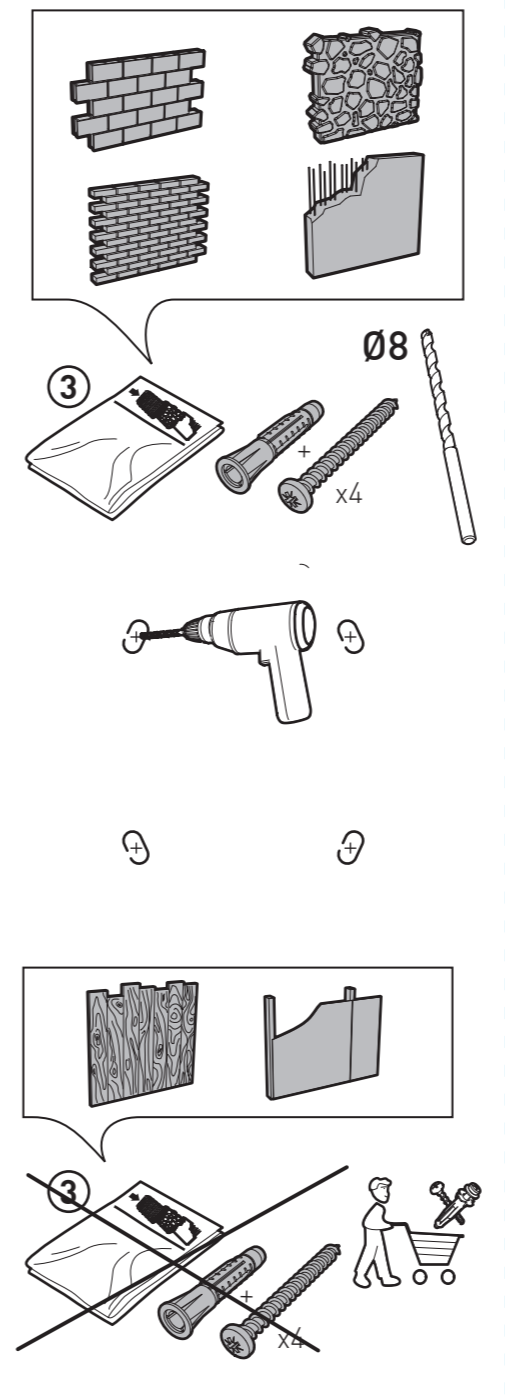

7

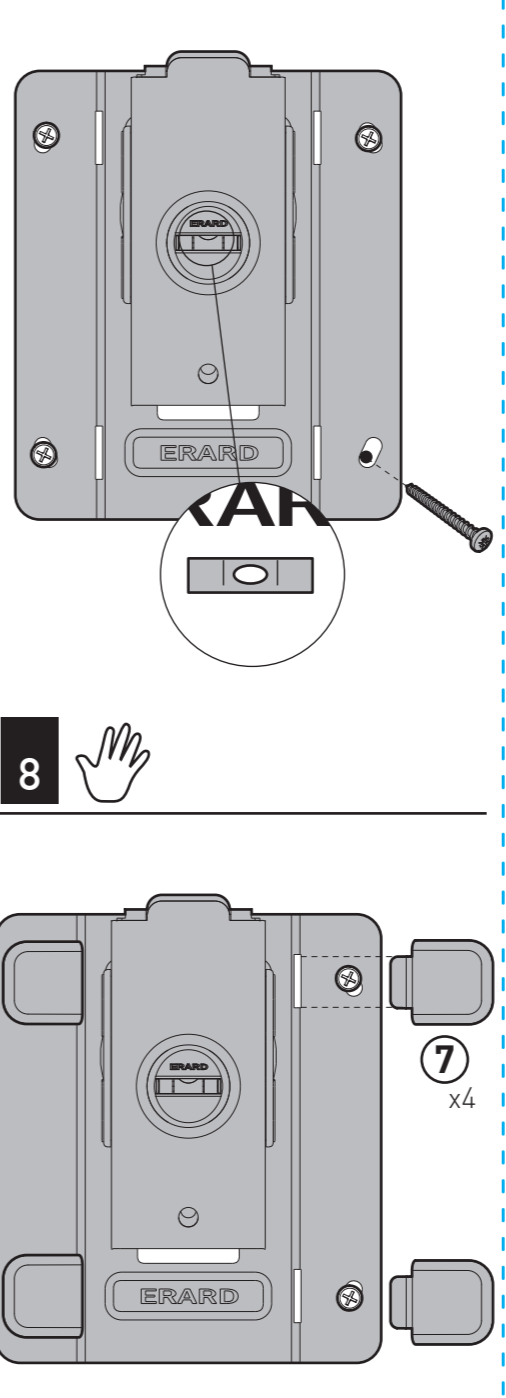

9

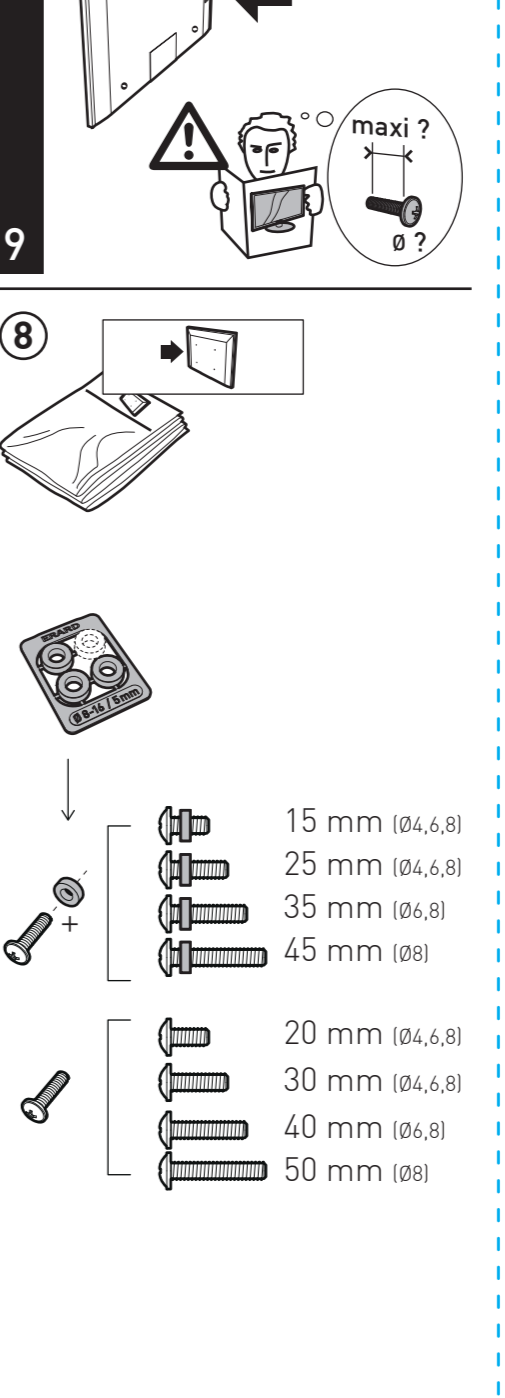

10

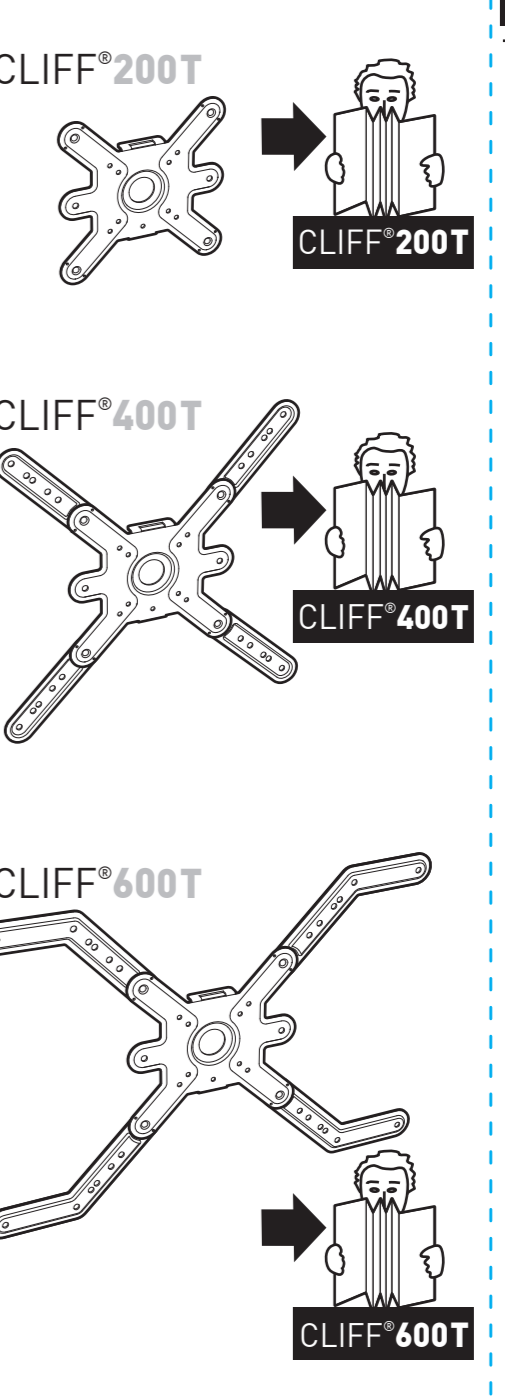

8

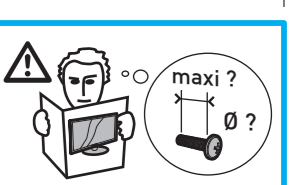
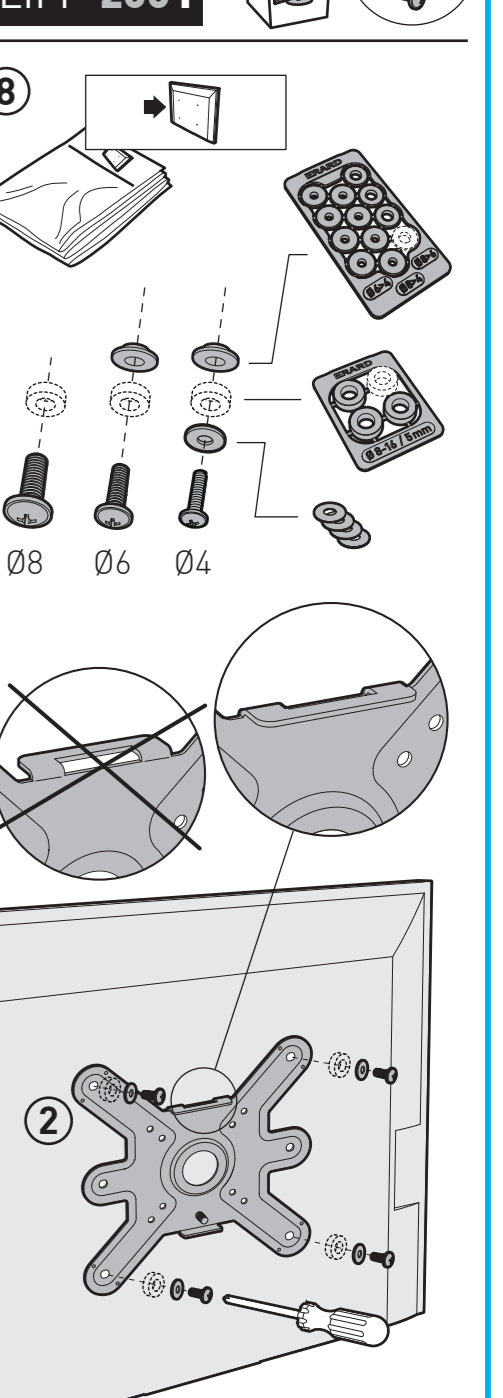

- 15 mm (Ø4,6,8)
- 25 mm (Ø4,6,8)
- 35 mm (Ø6,8)
- 45 mm (Ø8)
- 20 mm (Ø4,6,8)
- 30 mm (Ø4,6,8)
- 40 mm (Ø6,8)
- 50 mm (Ø8)

CLIFF®400T

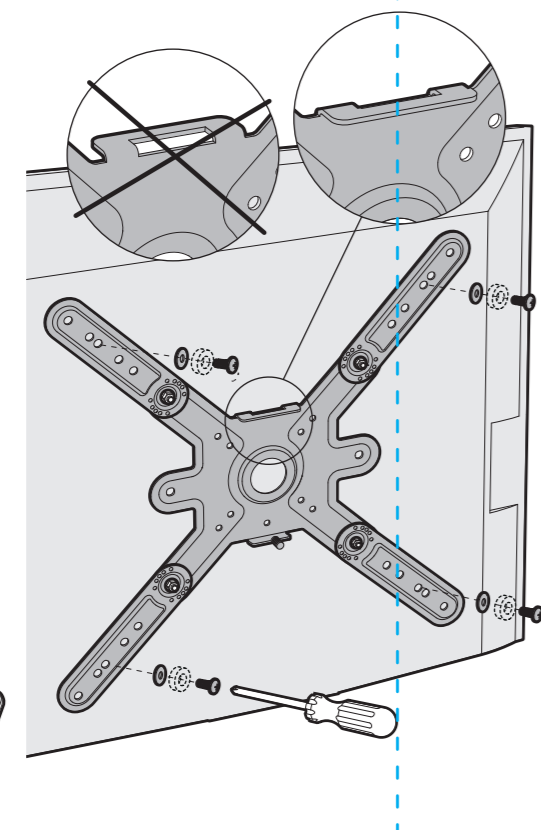
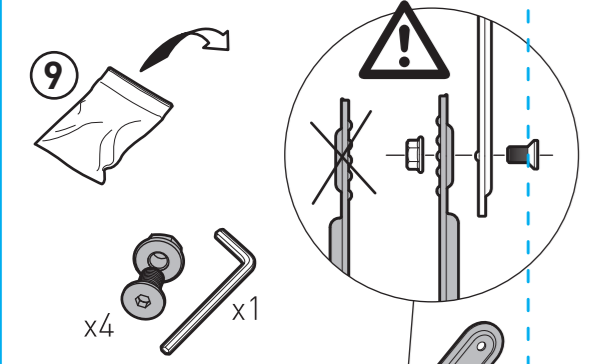
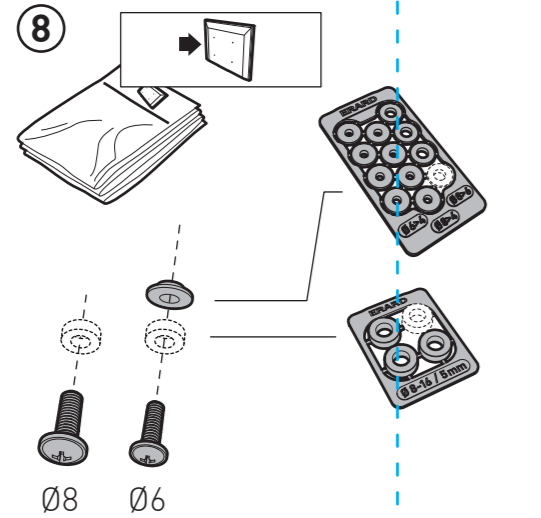
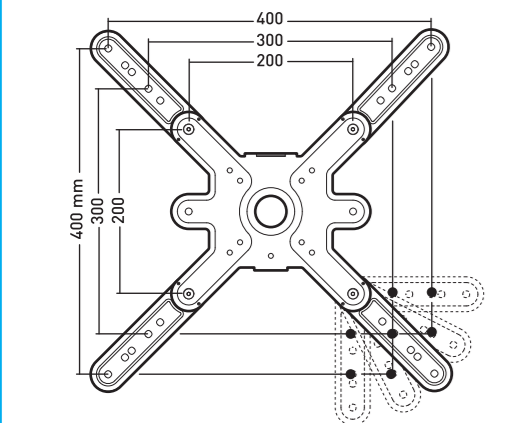

CLIFF®600T

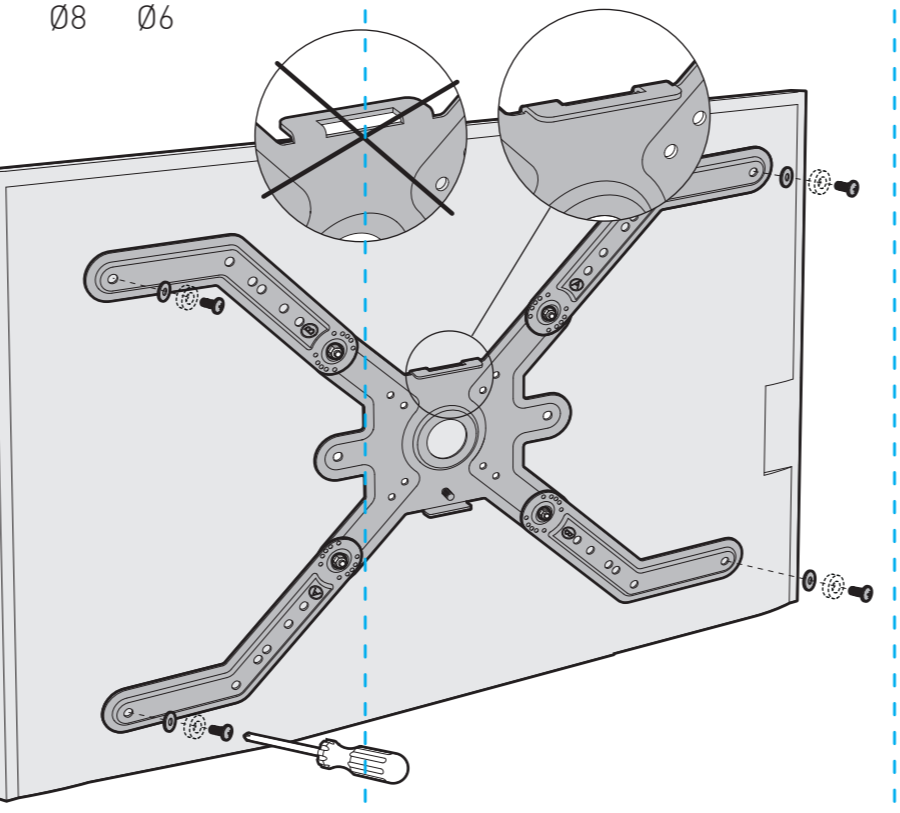
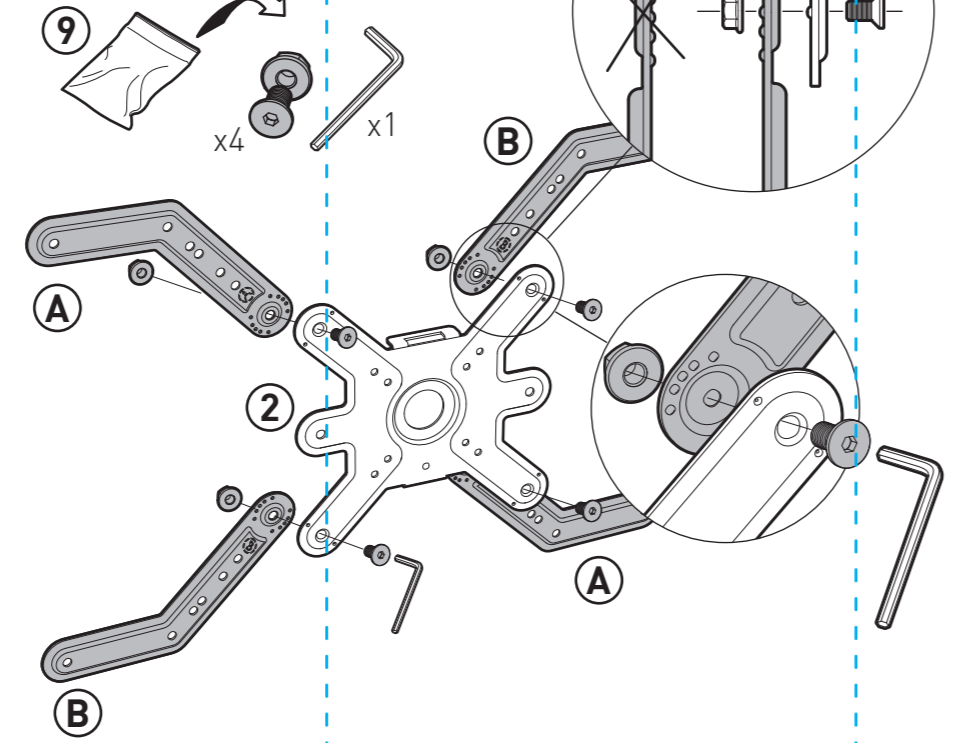
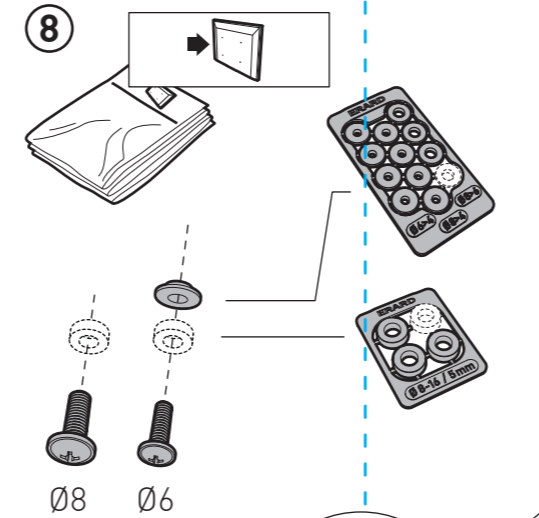
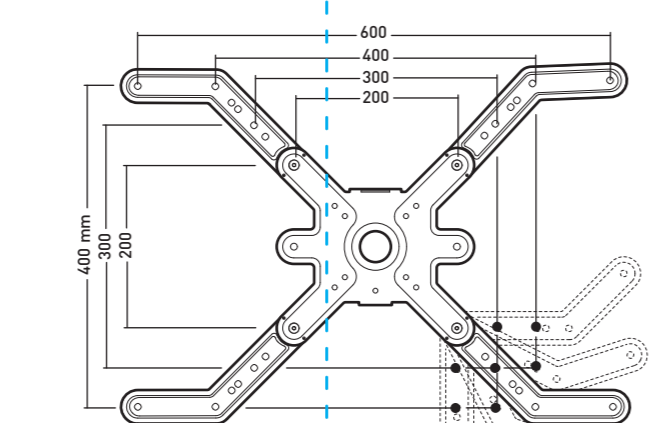

11

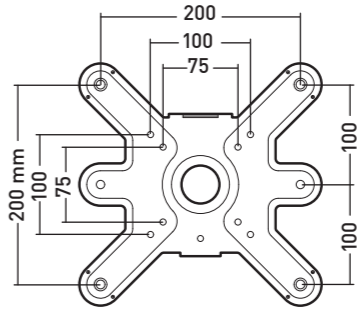
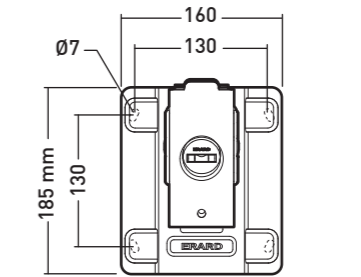
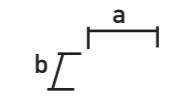
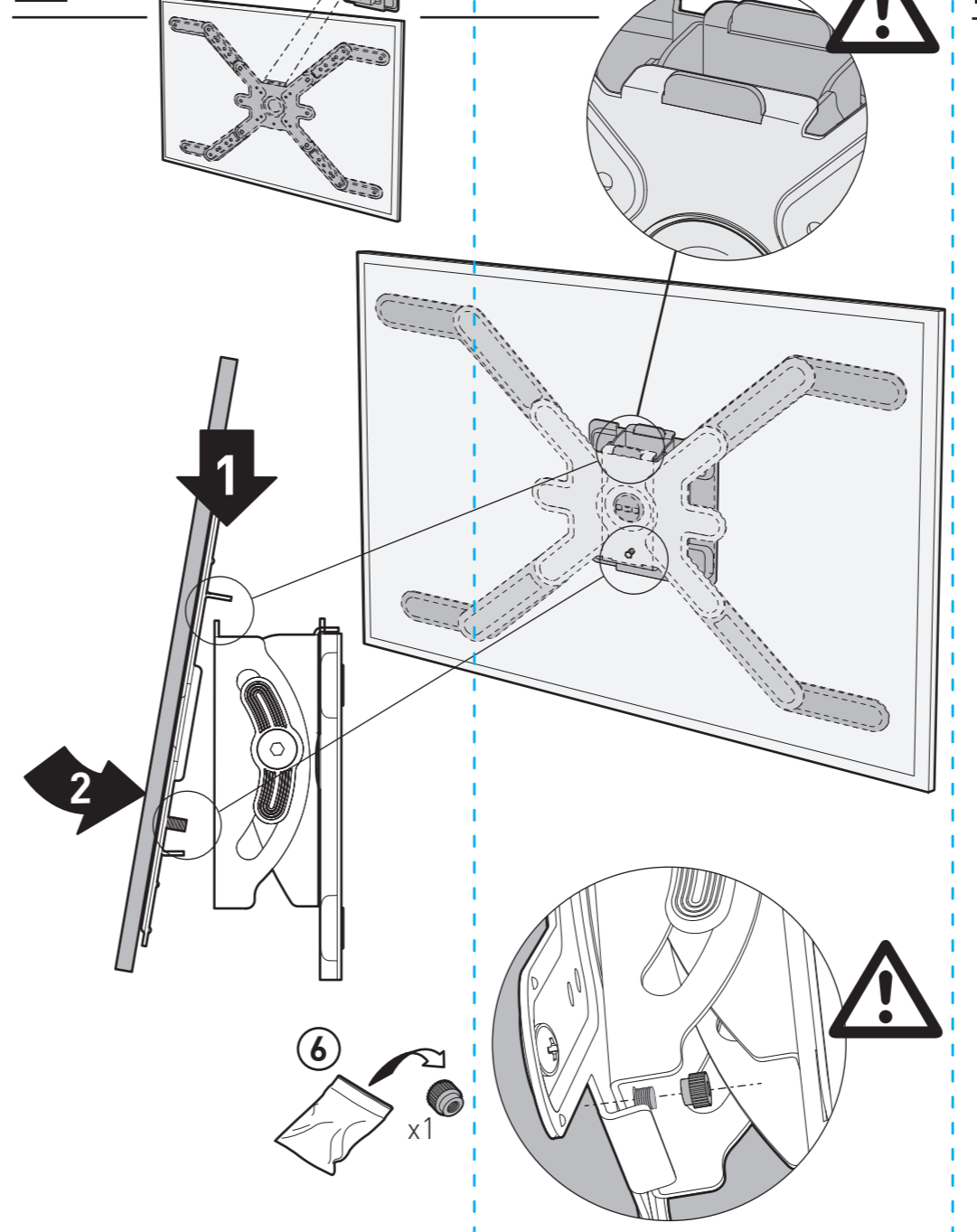

Vous avez des questions ?
Vous avez besoin de conseils ?
N° Vert 0 800 40 40 60
APPEL GRATUIT DEPUIS UN POSTE FIXE
international : +33 4 72 46 16 26
Fabriqué en France - Made in France
www.erard.com

Pensez à donner ou recycler.
Association
Magasin
Déchèterie

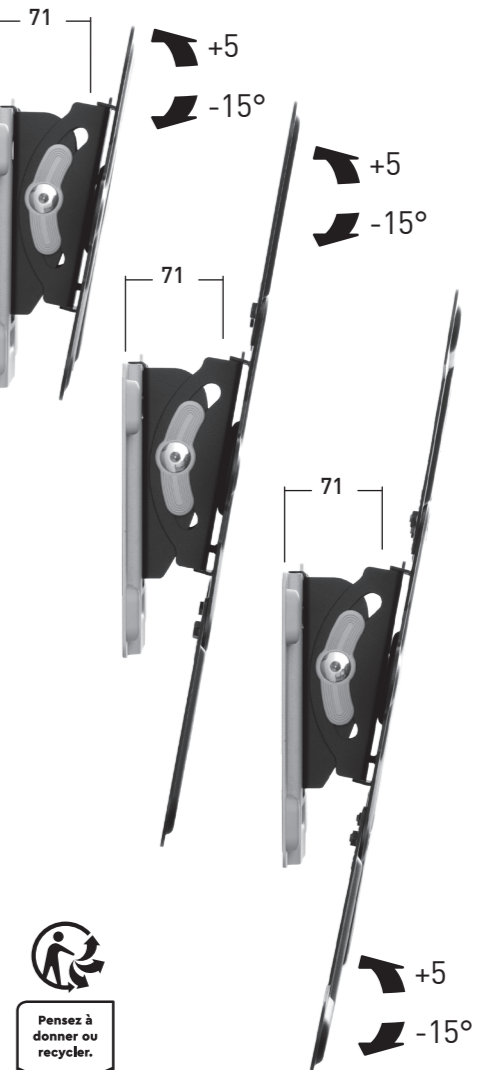

CLIFF®200T/400T/600T

SUPPORT MURAL INCLINABLE POUR ECRAN PLAT
TILTING WALL MOUNT FOR FLAT SCREEN

v.2.2

M
19"-43"
48-109 cm
30 KG
TESTÉ JUSQU'À 120 KG
TESTED UP TO 120 KG
REF: 043220

L
30"-65"
76-165 cm
30 KG
TESTÉ JUSQU'À 120 KG
TESTED UP TO 120 KG
REF: 043240

XL
40"-85"
101-215 cm
30 KG
TESTÉ JUSQU'À 120 KG
TESTED UP TO 120 KG
REF: 043260

